

Apply for a Pool Fence Permit



All residential swimming pools (a temporary inflatable pool, an in-ground pool, or an above ground pool) requires a pool fence under By-Law 07-4375 if the pool meets the following requirements:

- Any body of water having a depth of 600mm (24")
- Intended for swimming or wading
- *Hydro Massage pools with locking lids are excluded from this requirement.

SWIMMING POOL FENCE BY-LAW & ZONING BY-LAW REQUIREMENTS:

All pools, and accompanying structures are required to comply with the Zoning By-Law for location, setbacks, and coverage

1. All pools are required to be located in the rear or the side yard, and are not permitted in the front yard.
2. Minimum setback from interior side yard, and rear yard property lines to the pool wall is 1.2m (4'-0"). If the pool is placed in an exterior side yard (corner lot) the minimum setback is 3m (9'-10") from the street line.
3. Minimum height for a pool fence is 1.53m (5'-0") and is to be non-climbable from the exterior of the fence.
4. No openings in pool fence larger than 38 mm (1.5") however, if horizontal members of the fence are greater than 4' apart, no openings greater than 100mm (4") are permitted
5. Pool fence must have a self-closing and self-latching gate and must be locked at all times when not in use.
6. All pool sheds are required to meet the minimum zoning setbacks.

Example Sketch of Pool Fence By-Law Requirements:

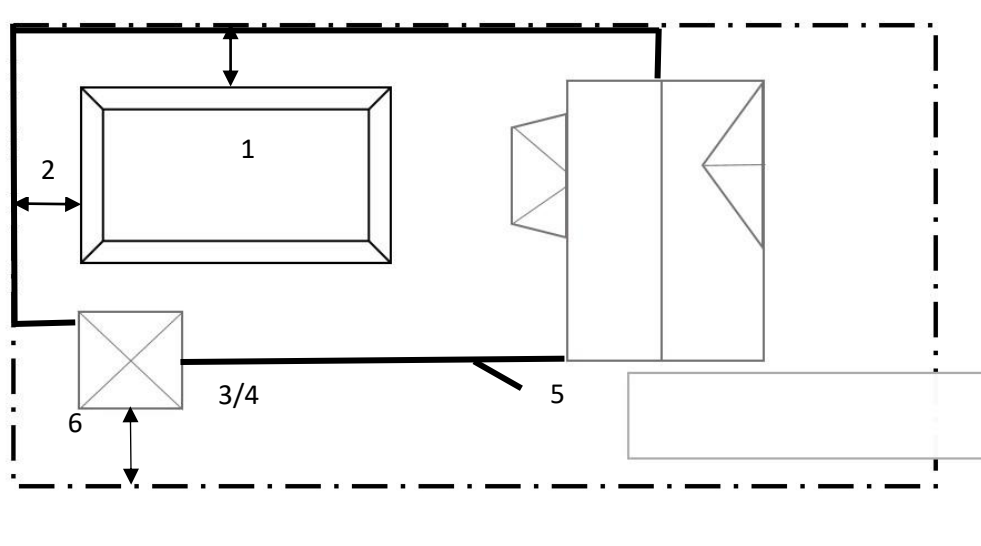

WHAT IS NEEDED TO APPLY

A complete building permit application for a Pool Fence Permit requires the following:

- A completed Building Permit Application Form (Click [HERE](#) to be redirected to our website)
- Two copies of the site plan showing:
 - The location of the pool
 - All existing and proposed structures, easements
 - Setbacks from property lines shall be fully dimensioned
 - Location of the proposed gate(s). (see example on previous sheet)
 - Lot coverage and open landscaped space calculations showing compliance with the Zoning By-Law. Lot coverage requirements apply to existing and proposed structures, including patios at grade and other hard surface areas. The area of the proposed pool is not included when calculating lot coverage.
- If you are installing an **In Ground** or **Semi-In Ground** pool you will need a lot grading plan completed by an Ontario Land Surveyor or Engineer detailing how the drainage of your property will work after the pool is completed. This is to ensure that alterations to your rear yard does not negatively affect the neighboring properties.
- If your backyard plans include a deck, shed, covered roof area, or gazebo, you will need to apply for that project under a separate building permit application.

POOL FENCE PERMIT FEES

The permit fees for a pool fence permit are as follows:

\$163 Base Fee

\$1000 Damage deposit (fully refundable once final inspection has past)

\$113 (with tax) Road Allowance Excavation Permit may apply (application is [HERE](#))

All permits may be applied for by email and sent to building@ingersoll.ca. Once your application has been submitted, within 2 business days you will receive an email detailing any outstanding required documents, your invoice, payment instructions, and next steps for your permit.

Further Swimming Pool Fence definitions, regulations, and enforcement can be found in Town of Ingersoll **By-Law 07-4375**.